

HPS SERIES

HIGH PERFORMANCE MOTORS
STAND ALONE MOTOR (HPS RANGE)

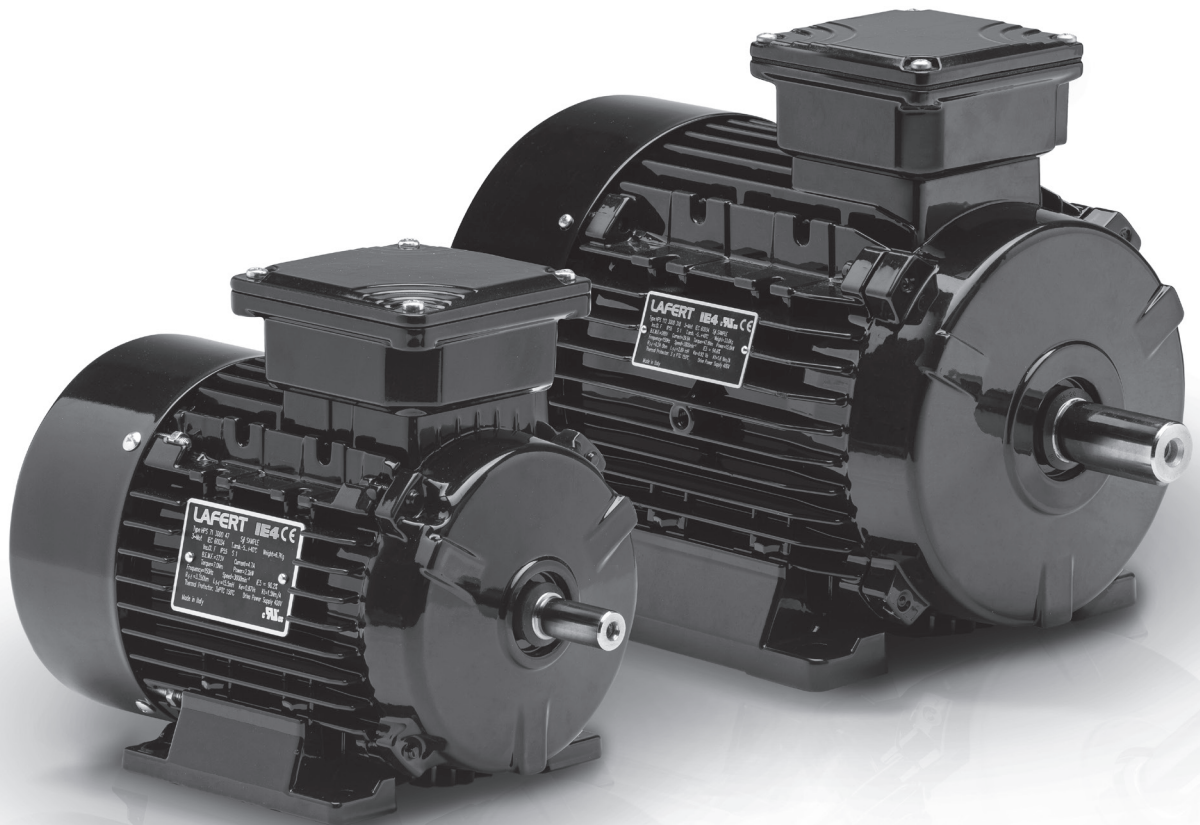

IE4 

HPS CATALOGUE 2019



CONTENTS

PRODUCT RANGE	3
MERGING TECHNOLOGIES	5
TECHNICAL DESCRIPTION	8
Brief Description	
Definitions	
STANDARDS AND REGULATIONS	9
CONDITIONS OF INSTALLATION	12
Electrical/Mechanical Tolerances	
Thermal Protection and Derating	
Derating for Ambient Temperature, Air pressure & Low Speed	
MECHANICAL DESIGN	15
Mounting arrangements	
Bearing lubrication and maintenance	
Cooling	
Vibration	
MOTOR NAMEPLATE	18
PERFORMANCE DATA	19
METRIC DIMENSIONS	24
NEMA DIMENSIONS	28

MISSION

The Lafert Group, a leading European Motor Company, is committed to continuous growth by being the global leading manufacturer of **customised engineered Electric Motors and Drives** with specific focus on Industry Automation, Energy Saving, and Renewables.

The Lafert Group will strive to be the ideal partner in the Electric Motors and Drives industry through focus on meeting specific customer demands. Mutually beneficial partnerships are developed by continuous process improvements utilising state-of-the-art products and techniques by a skilled, motivated and professional workforce.

ONE IS DIFFERENT FROM THE OTHER. SIMPLY UNIQUE.

Lafert design and build customised electric motors with unique characteristics, because the needs of our customers are unique. The control of the whole manufacturing process allows for any aspect of the motor to be modified. This gives the ability to engineer customized motors that fit the final application/work environment for maximum efficiency and reliability.

Lafert leverages over 50 years of experience in partnering with Global Companies from its 12 locations spread across Europe, North America, Asia and Australia.



1 ≠ 1

One is different from the other.
Simply unique.

HPRANGE, Permanent Magnet Synchronous Motors and Drives, Super Premium Efficiency – IE4/IE5, IPM and SMPM technology, designed for HVAC applications

HP RANGE

THE IE4 AVAILABLE SOLUTION

High Performance (HP) is a generation of **PM (Permanent Magnet) Synchronous Motors**, achieving **IE4 and IE5 Super Premium Efficiency** level, that offer improved electrical efficiency at stable and reduced production costs without applying rare earth magnets.

This uniquely engineered product combines the electrical design of Brushless Servomotors with the mechanical design of AC Induction Motors. The result is a compact motor primarily targeted toward HVAC applications in fans, compressors, and blowers, where there is emphasis on reducing the operating cost or weight and size of the motors.

The complete range 0.37 kW to 37 kW are supplied as **stand-alone motors** (HPS) to be controlled by a separate drive, specifically designed for their energy saving potential.



The Awards



2013 European New Product Innovation Leadership Award: Electric Motors for HVAC Applications by Frost & Sullivan



2014 AHR Expo Innovation Awards: Green Building Category



ADI Index Design 2012: Best Italian design in manufacturing

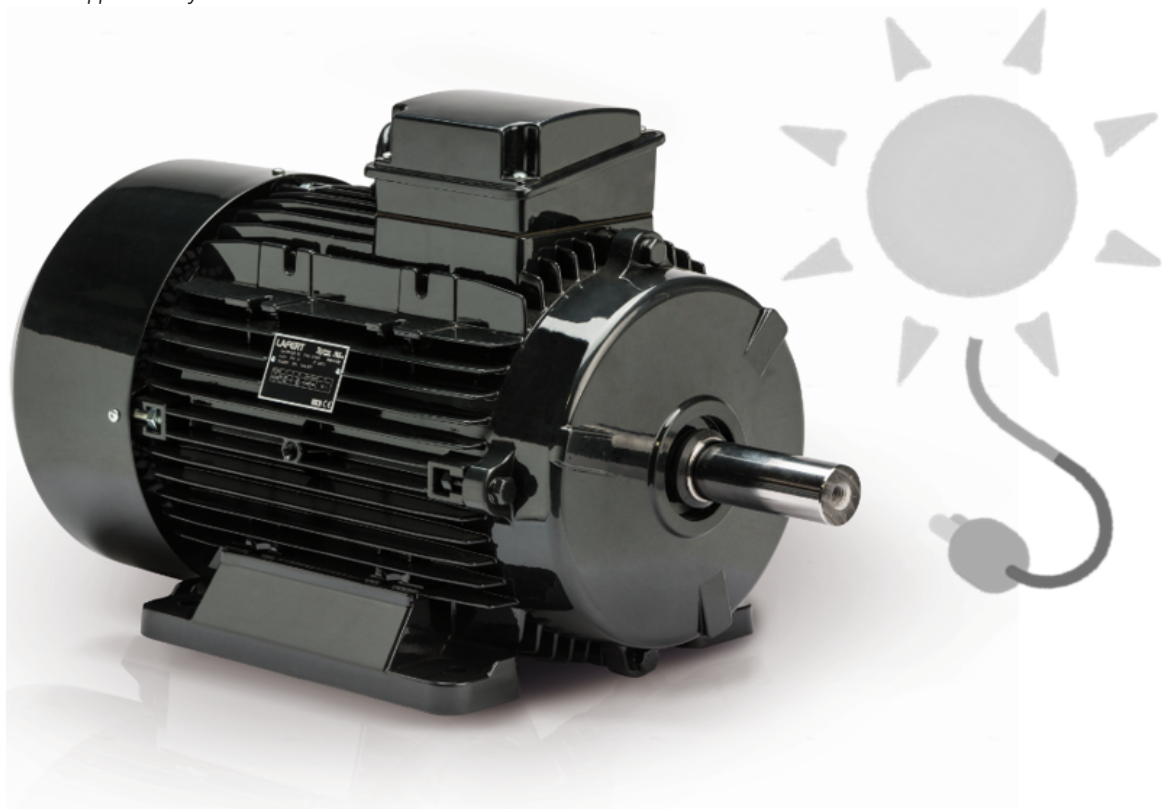

LEVERAGING LEADING-EDGE TECHNOLOGIES

High Performance Motors (HPS) are an innovative range of **PM (Permanent Magnet) Synchronous Motors**, achieving **IE4 Super Premium Efficiency** level that offer improved efficiency and reduced operating costs.

Lafert's in house servo and AC induction motor design and manufacturing capabilities have facilitated the development of this uniquely engineered range of Permanent Magnet IE4 Synchronous Motors.

In order to develop the HP Motor, Lafert used a combination of product designs inspired by the brushless servo motor's electrical design and the AC induction motor's mechanical design.

With higher efficiencies than standard AC induction motors they also enhance the power/weight ratio, thereby allowing for significant **size and weight reductions of up to 50%**.

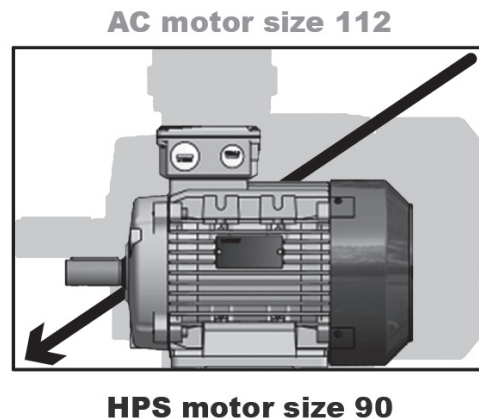

The Lafert PM rotor technology of the HP motor has no losses. Also, stator currents are lower, consequently generating lower losses due to lower current demand (Joule effect). The resulting benefit is a lower rated temperature rise for both the windings and bearings. These limited temperature rises can, in the right design, eliminate the need for a cooling fan and its related losses. Ultimately, the sum of these minimised heat contributions provide higher running speeds and extended bearing life.

Lafert place great emphasis on materials research. This has resulted in reduced dependency on rare earth magnets, allowing the use of more readily available permanent magnets, which ensures price and supply stability into the future. Following this development work Lafert have introduced a **second generation of PM Synchronous Motors**, named HPF, achieving **IE4 Super Premium Efficiency** level, with more stable and reduced production costs **without applying rare earth magnets**.

VALUE ADDED FEATURES & BENEFITS

The primary benefit offered by Lafert's HP synchronous motor is the reduction in the life cycle cost of the motor. The combination of servo brushless and induction motor technology used for the development of this product gives it a high efficiency low noise design. Because of the higher efficiency, the product dissipates lower heat, which improves its operating life.

This motor is primarily targeted toward **HVAC applications** in pumps, fans, compressors, and blowers, where there is an emphasis on reducing the operating cost or weight, and size of the motors. Lafert also offers flexibility in terms of design, customising the active and mechanical parts of the motor to suit specific customer requirements.

Lafert also has the ability to produce this motor in high volume on a regular scheduled delivery basis with modifications as per specific customer requirements. The HP PM synchronous motor is available in a range of power outputs, ranging **from 0.37 kW to 37kW**, with full flexibility in motor speed up to 6000 RPM; it can be controlled by most standard drives.



INCREASED CUSTOMER ROI

The high operating efficiency offered by Lafert's PM synchronous motor leads to lower electricity consumption costs. The uniquely efficient design also improves the life of this motor, thereby reducing potential down time and refitting costs.

The product meets the IE4 efficiency class at all operating speeds, making it one of the most efficient electric motors available in the European market. This is ahead of the mandatory efficiency requirements set by the European Union, currently for IE2 and IE3 motors.

LAFERT PM MOTORS' AWARDS



Based on **Frost & Sullivan's** Best Practices independent research, Lafert have been granted the **2013 European New Product Innovation Leadership Award** in Electric Motors for Heating Ventilation Air Conditioning (HVAC) Applications.



The High Performance Motor from Lafert has been awarded as the winner in the **Green Building Category of the 2014 AHR Expo Innovation Awards Competition**.

RANGE OF PRODUCTS

A range of solutions to meet specific demand:

- **Stand-alone drive** (HPS range)
- Sensorless control or with speed transducer
- **IPM** (Interior Permanent Magnets) or **SMPM** (Surface Mounted Permanent Magnets) **design**, depending on the performance demand

BRIEF DESCRIPTION

The following features of our HP Motors may vary depending on series and type:

- Admissible environmental temperature: from -15 °C up to +40 °C, with altitudes 1000 m above sea level
- Mounting: IM B3, B5, B14, B34, B35
- Flange concentricity degree "N"; balancing: vibration "A/B"; dynamic balancing with half key
- Shaft designed according to the standard version with key (also available without key)
- Available speeds: 1500, 1800, 3000, 3600, 4500 rpm (others on request)
- Drive operating voltage: 230 or 400 Vac
- Insulation class: "F"; temperature rise to class B (TEFC execution)
- IP55 degree of protection for the whole range
- On-Off PTO switch for thermal protection (NTC and PTC are available)
- Optional feedback on request: resolver, encoder, tacho and Hall sensors (several combinations may be added to this list)
- Reduced dimensions
- Permanent magnets technology

DEFINITIONS

- **HPS:** High Performance Stand alone motors to be controlled by a separate drive (SENSORLESS)
- **Rated torque (Mn):** Torque available on the shaft continuously (service S1) with rated speed and with a winding current equivalent to the rated current, holding the motor in rated working condition.
- **Peak torque (Mpk):** Torque available on the shaft discontinuously, with a winding current equivalent to the peak current.
- **Rated current (In):** Current supplied to the motor continuously at a rated speed, required to develop rated torque.
- **Peak current (Ipk):** Current supplied to the motor discontinuously within a wide range of speed, required to develop peak torque without exceed the thermal class of motor.
- **Voltage constant (Ke):** Ratio between voltage induced by the rotor rotation (RMS value for sinusoidal motor, peak value for trapezoidal motor) at a certain number of revolutions and angular speed ($\omega = 2 \times \pi \times n / 60$ where n is the speed expressed in rpm) measured in rad/sec.
- **Torque constant (Kt):** Ratio between torque on the shaft and the current RMS value for sinusoidal motors, peak value for trapezoidal motors (equivalent to the voltage constant of a trapezoidal motor and to that of a sinusoidal motor multiplied by $\sqrt{3}$).
- **Back electromotive force (B.E.M.F):** Voltage induced by the rotor rotation (RMS value for sinusoidal motor, peak value for trapezoidal motor) at a certain number of revolutions.



QUALITY SYSTEM CERTIFICATE

The strictness of our quality control assures the flawless operation and reliability of our products. Our quality is confirmed by the **Certificate ISO 9001:2015** awarded by KIWA-CERMET, a certification body authorized by ACCREDIA.

SAFETY STANDARDS

Our motors comply with the requirements of the International Standard **IEC 60034** for rotating electrical machines as well as with the following European Directives: **Low Voltage Directive (LV) 2014/35/EC**, **Electromagnetic Compatibility Directive (EMC) 2014/30/EC**.

All products comply with the requirements of the **Directive Machines (MD) 2006/42/EC**. In accordance with this Directive, induction motors are components and intended solely for integration into other machines. Commissioning is forbidden until conformity of the end-product with this Directive is proved.



The CE marking was applied for the first time in 1995.

When operating the motor, the observance of the Regulation EN 60204-1 and safety instructions indicated in our Operating Instructions must be complied with.

Motors complied with many other international standards are available on request:



Motors approved by UL Underwriters Laboratories Inc.

EFFICIENCY STANDARDS

The HPS motors comply with:

IEC TS 60034-30-2: Rotating electrical machines - Part 30-2: Efficiency classes of variable speed AC motors (IE-code)

EFFICIENCY VALUES ACCORDING TO IEC 60034-30-2:2016

Efficiencies are harmonized to the **International Standard IEC 60034-30-2:2016** that extends the efficiency levels to Super Premium Efficiency IE4 and IE5.

Output kW	IE4 REFERENCE LIMIT				IE5 REFERENCE LIMIT			
	Rated speed within 600 to 900 /min	Rated speed within 901 to 1200 /min	Rated speed within 1201 to 1800 /min	Rated speed within 1801 to 6000 /min	Rated speed within 600 to 900 /min	Rated speed within 901 to 1200 /min	Rated speed within 1201 to 1800 /min	Rated speed within 1801 to 6000 /min
0.12	62.3	64.9	69.8	66.5	67.4	69.8	74.3	71.4
0.18	67.2	70.1	74.7	70.8	71.9	74.6	78.7	75.2
0.2	68.4	71.4	75.8	71.9	73	75.7	79.6	76.2
0.25	70.8	74.1	77.9	74.3	75.2	78.1	81.5	78.3
0.37	74.3	78	81.1	78.1	78.4	81.6	84.3	81.7
0.4	74.9	78.7	81.7	78.9	78.9	82.2	84.8	82.3
0.55	77	80.9	83.9	81.5	80.6	84.2	86.7	84.6
0.75	78.4	82.7	85.7	83.5	82	85.7	88.2	86.3
1.1	80.8	84.5	87.2	85.2	84	87.2	89.5	87.8
1.5	82.6	85.9	88.2	86.5	85.5	88.4	90.4	88.9
2.2	84.5	87.4	89.5	88	87.2	89.7	91.4	90.2
3	85.9	88.6	90.4	89.1	88.4	90.6	92.1	91.1
4	87.1	89.5	91.1	90	89.4	91.4	92.8	91.8
5.5	88.3	90.5	91.9	90.9	90.4	92.2	93.4	92.6
7.5	89.3	91.3	92.6	91.7	91.3	92.9	94	93.3
11	90.4	92.3	93.3	92.6	92.2	93.7	94.6	94
15	91.2	92.9	93.9	93.3	92.9	94.3	95.1	94.5
18.5	91.7	93.4	94.2	93.7	93.3	94.6	95.3	94.9
22	92.1	93.7	94.5	94	93.6	94.9	95.5	95.1
30	92.7	94.2	94.9	94.5	94.1	95.3	95.9	95.5
37	93.1	94.5	95.2	94.8	94.4	95.6	96.1	95.8
45	93.4	94.8	95.4	95	94.7	95.8	96.3	96
55	93.7	95.1	95.7	95.3	94.9	96	96.5	96.2
75	94.2	95.4	96	95.6	95.3	96.3	96.7	96.5
90	94.4	95.6	96.1	95.8	95.5	96.5	96.9	96.6
110	94.7	95.8	96.3	96	95.7	96.6	97	96.8
132	94.9	96	96.4	96.2	95.9	96.8	97.1	96.9

For the nominal efficiency calculation refer to the IEC 60034-30-2:2016.

The HPS motors comply with the relevant standards and regulations, especially:

ELECTRICAL	Rating and performance	IEC 60034-1
	Efficiency classes of variable speed AC Motors (IE-CODE)	IEC 60034-30-2
	Terminal markings and direction of rotation of rotating electrical machines	IEC 60034-8
	Selection of Energy-efficient motors including variable speed applications-application guide	IEC/ST 60034-31
	Insulating materials	IEC 60085
MECHANICAL	Dimensions and output ratings	IEC 60072
	Mounting dimensions and relationship frame sizes-output ratings, IM B3, IM B5, IM B14	IEC 60072
	Cylindrical shaft ends for electric motors	IEC 60072
	Degrees of protection	IEC 60034-5
	Methods of cooling	IEC 60034-6
	Mounting arrangements	IEC 60034-7
	Mechanical vibration	IEC 60034-14
	Mounting flanges	DIN 42948
	Tolerances of mounting and shaft extensions	DIN 42955
	Classification of environmental conditions	IEC 60721-2-1
	Mechanical vibration; balancing	ISO 8821

VIBRATION AND SHOCK

HPS Motors have been tested according to a procedure based on the following standards:

- IEC 60068-2-6: Vibration (sinusoidal) - 1970
- IEC 60068-2-34: Random vibration broad-band- general requirements
- IEC 60068-2-35: Random vibration broad-band- high reproducibility
- IEC 60068-2-36: Random vibration broad-band- medium reproducibility

HPS Motors comply with requirements that correspond to conditions in the standards mentioned above.

AIR HUMIDITY

HPS Motors have been designed to meet the IEC 60068-2-3 standard, EN 50178 item 9.4.2.2/DIN 40040, class E, at 40°C.
Cyclic damp heat according to IEC 60068-2-30, 40°C.

DEGREES OF PROTECTION

Degrees of mechanical protection for machines are designated in accordance with **IEC 60034-5** by the letters **IP** and two characteristic numerals.

First numeral: Protection against contact and ingress of foreign bodies

Second numeral: Protection against ingress of water

IP	Description	IP	Description
5	Protection against dust (harmful deposits of dust)	5	Protection against water projected by a nozzle from any direction
6	Complete protection against dust	6	Protection against heavy seas or water projected in powerful jets

ELECTRICAL TOLERANCES

For industrial motors to **EN 60034-1**, certain tolerances must be allowed on guaranteed values, taking into consideration the necessary tolerances for the manufacture of such motors and the materials used. The standard includes the following remarks:

- 1- It is not intended that guarantees necessarily have to be given for all or any of the items involved. Quotations including guaranteed values subject to tolerances should say so, and the tolerances should be in accordance with the table.
- 2- Attention is drawn to the different interpretation of the term guarantee. In some countries a distinction is made between guaranteed values and typical or declared values.
- 3- Where a tolerance is stated in only one direction, the value is not limited in the other direction.

Values for	Tolerance
Efficiency (η) (by indirect determination)	- 0.15 (1 - η) at $P_N \leq 150$ kW - 0.1 (1 - η) at $P_N > 150$ kW
Power factor ($\cos \varphi$)	$\frac{1 - \cos \varphi}{6}$, minimum 0.02, maximum 0.07
Rated current with rated torque and revolutions (measurement in S1 duty cycle at rated speed with $\vartheta_{amb} \leq 40$ °C and altitude ≤ 1000 m above sea level)	In +/- 5%
Back electromotive force: Bemf	Bemf +/- 5%
Peak torque (M_K)	- 10 % of the guaranteed value (after allowing for this tolerance, M_K/M_N not less than 1.6)
Moment of inertia (J)	± 10 % of the guaranteed value

MECHANICAL TOLERANCES

Motors have to be installed according to their mounting arrangements defined by **IEC 60034-7**, Code I (in brackets Code II). The mechanical components may be designed in order to work as for the motor mounting code.

According to **IEC 60072-1**, the following tolerances on mechanical dimensions of electric motors are permitted:

Parameter	Code	Tolerance
Shaft height	H	- up to 132 -0.5 mm
Diameter of shaft end¹⁾	D	- from 11 to 28 mm j6 - from 38 to 48 mm k6
Hub key width	F	h9
Flange spigot	N	- up to 132 j6 - over size 132 h6

1) Centring holes in shaft extension to DIN 332 part 2

THERMAL PROTECTION AND DERATING

The HPS Motors are thermally protected in case limits are exceeded (140°C), another protection is provided through the drive.

DERATING FOR AMBIENT TEMPERATURE

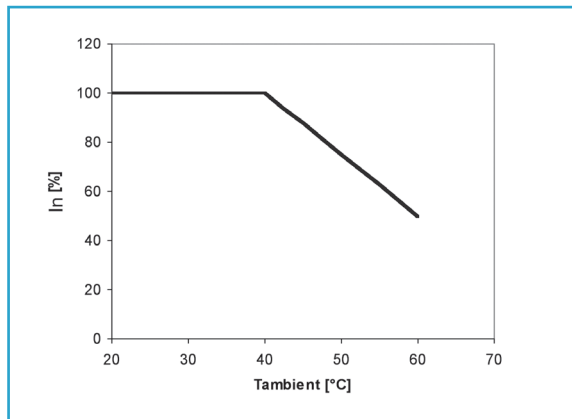

The ambient temperature (TAMAX) is the maximum temperature allowed. If HPS Motor is operated at temperatures above 40 °C, a derating of the continuous output current is necessary.

DERATING FOR AIR PRESSURE

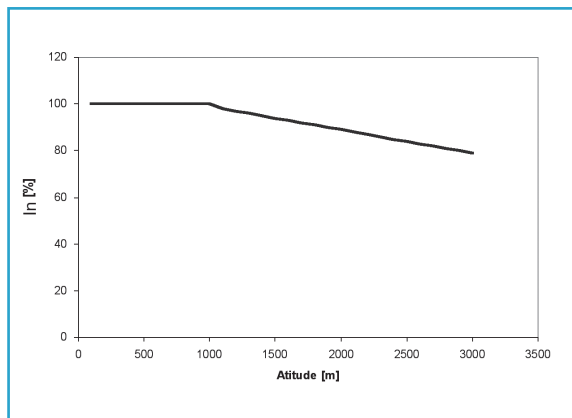

Below 1000 m altitude no derating is necessary. Above 1000 m the ambient temperature (TA) or max. rated output current (IN) must be derated in accordance with the following diagram.

See the below diagram for derating of output current versus altitude at TA = max. 40°C

DERATING FOR RUNNING AT LOW SPEED

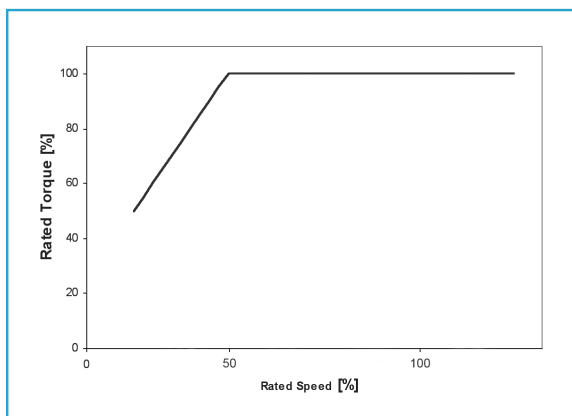

When a centrifugal pump or a fan is controlled by a HPS Motor, it is not necessary to reduce the output at low speed because the load characteristic of the centrifugal pumps/fans, automatically ensures the necessary reduction.

HPS motors running constant load torque applications continuously at low speed must be derated (see diagram as example) or an independent fan must be used.

HPS ELECTRICAL CONNECTION

The stand-alone HPS motor can NOT be installed directly on the mains. HPS motor needs always to be controlled by a drive.

The 3 phases from the drive needs to be connected to U1, V1, W1 (Please see DWG 1).

HPS motors covered in this catalogue are all related to 400V data, and are designed for one supply voltage. It is not possible to make star/delta connections in the terminal box like on an AC motor. HPS motor is in general 3*400V but can also be delivered for 3*230V.

Rotation direction: there are two ways to change the rotating direction of the HPS motor. First of all by changing the sequences of 2 phases from the drive or by having the drive to change the rotating direction via the software (Please see DWG 2).

Warning: please be aware that when turning the shaft and without any connection to the drive, the HPS motor will work as a generator and deliver a voltage level (BEMF Voltage) according to the rotating speed.

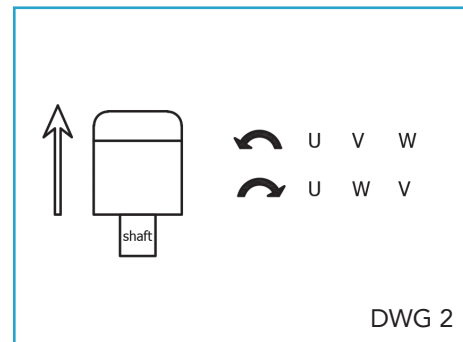
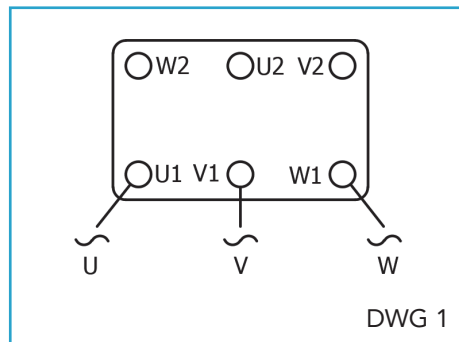

MOUNTING ARRANGEMENTS

Mounting arrangements for rotating electrical machines are designated according to IEC 60034-7, Code I (in brackets Code II).

Foot mounting

Flange mounting

IM B3 (IM 1001)

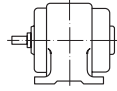

IM B5 (IM 3001)
Flange type A to DIN 42 948 at drive end

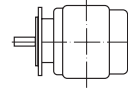

IM B6 (IM 1051)

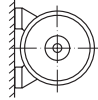

IM V1 (IM 3011)
Flange type A to DIN 42 948 at drive end

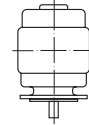

IM B7 (IM 1061)

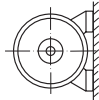

IM V3 (IM 3031)
Flange type A to DIN 42 948 at drive end

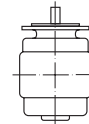

IM B8 (IM 1071)

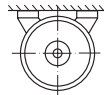

IM B35 (IM 2001)
Flange type A to DIN 42 948 at drive end

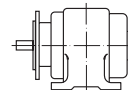

IM V5 (IM 1011)

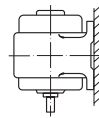

IM B14 (IM 3601)
Flange type C to DIN 42 948 at drive end

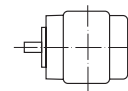

IM V6 (IM 1031)

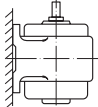

IM V18 (IM 3611)
Flange type C to DIN 42 948 at drive end

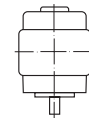

IM B34 (IM 2101)
Flange type C to DIN 42 948 at drive end

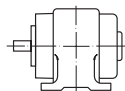

IM V19 (IM 3631)
Flange type C to DIN 42 948 at drive end

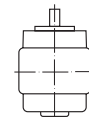

It is essential to state the desired mounting arrangement when ordering, as the constructive design depends partly on the mounting arrangement.

BEARING LUBRICATION AND MAINTENANCE

All motors have bearings type 2ZC3 with grease suitable for high and low temperature and permanent lubrication.

Frame size	Speed rpm	DE	NDE
56	Up to 4500	6202 2Z C3	6201 2Z C3
71	Up to 4500	6205 2Z C3	6303 2Z C3
90	Up to 4500	6206 2Z C3	6304 2Z C3
112	Up to 3600	6208 2Z C3	6306 2Z C3
132	Up to 3600	6309 2Z C3	6208 2Z C3
160	Up to 3600	6310 2Z C3	6310 2Z C3

PERMISSIBLE AXIAL FORCES

Maximum permissible axial forces without additional radial forces*

Frame size	Horizontal shaft					Vertical shaft force upwards					Vertical shaft force downwards				
	4500	3600	3000	1800	1500	4500	3600	3000	1800	1500	4500	3600	3000	1800	1500
	min ⁻¹	min ⁻¹	min ⁻¹	min ⁻¹	min ⁻¹	min ⁻¹	min ⁻¹	min ⁻¹	min ⁻¹	min ⁻¹	min ⁻¹	min ⁻¹	min ⁻¹	min ⁻¹	min ⁻¹
56	-	-	-	-	-	-	-	-	-	-	-	-	-	-	-
71	0.25	0.26	0.27	0.30	0.31	0.24	0.25	0.26	0.29	0.29	0.24	0.24	0.25	0.28	0.29
90 S-L	0.63	0.65	0.66	0.68	0.70	0.60	0.62	0.63	0.65	0.67	0.59	0.61	0.62	0.64	0.66
112 M	-	0.88	0.98	0.99	1.10	-	0.79	0.88	0.89	0.99	-	0.29	0.30	0.31	0.35
112 XL	-	0.87	0.97	0.98	1.09	-	0.78	0.87	0.88	0.98	-	0.72	0.75	0.76	0.78
132 M	-	0.87	0.97	0.98	1.09	-	0.71	0.80	0.80	0.89	-	0.84	0.94	0.95	1.05
132 XL	-	0.86	0.96	0.97	1.08	-	0.71	0.79	0.80	0.89	-	0.83	0.93	0.94	1.05
132 XXL	-	0.84	0.95	0.96	1.05	-	0.69	0.78	0.79	0.86	-	0.81	0.92	0.93	1.02

Values for 50 Hz. For service on 60 Hz, reduce values by 10%

* Consult according to direction of force

PERMISSIBLE RADIAL FORCES

Without additional axial force (Ball bearings)

Nominal life= 20.000 h (Lh10)

FR= permissible radial force in kn in load point corresponding to half shaft extension

Frame size	4500 min ⁻¹ kN	3600 min ⁻¹ kN	3000 min ⁻¹ kN	1800 min ⁻¹ kN	1500 min ⁻¹ kN
71	0.57	0.58	0.60	0.64	0.66
90 S-L	0.84	0.85	0.87	0.88	0.90
112 M	-	1.35	1.37	1.39	1.43
112 XL	-	1.37	1.40	1.42	1.45
132 M	-	2.50	2.55	2.59	2.60
132 XL	-	2.56	2.59	2.60	2.65
132 XXL	-	2.60	2.63	2.65	2.70

COOLING

TEFC execution as standard.
Surface cooling, independent of the direction of rotation.

VIBRATION

The amplitude of vibration in electric motors is governed by EN 60034-14 **Mechanical vibration of rotating electrical machines with shaft heights 56 and larger - methods of measurement and limits.**

Standard motors are designed to vibration grade A (normal). Vibration grade B is available at extra cost.

Rotors are at present dynamically balanced with **half** key fitted as per DIN ISO 8821. Other balancing only on request.

The motors are identified as follows:

“H” or “blank” means balanced with **half key**

“F” means balanced with **full key**

“N” means **no key**

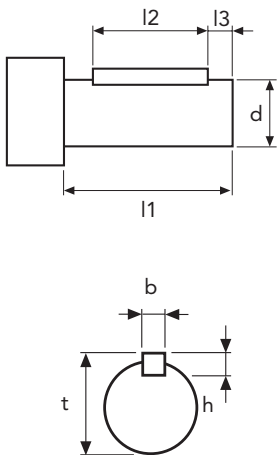

POSITION AND DIMENSIONS OF KEY

Frame size	d x l1	b x h	l2	l3	t
56	14 x 30	5 x 5	20	6	16
71	19 x 40	6 x 6	30	6	21.5
90	24 x 50	8 x 7	40	6	27
112	28 x 60	8 x 7	50	6	31
132	38 x 80	10 x 8	70	6	41
160	42x110	12 x 8	100	6	45

Dimensions in mm.

For larger shafts in special design the dimensions l2 and l3 are maintained.

NAMEPLATE EXAMPLE - HPS RANGE

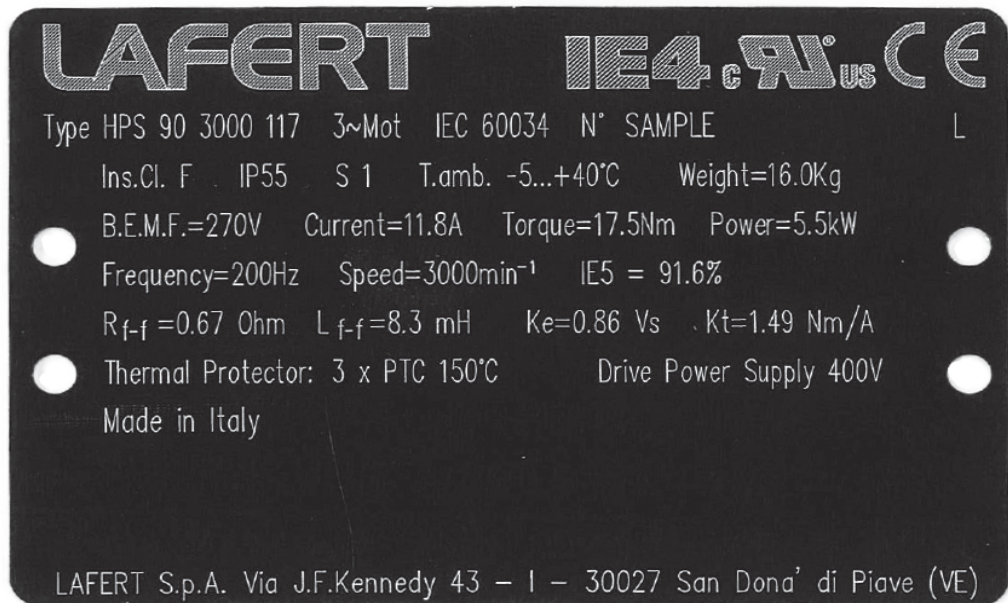

HPS - STAND ALONE MOTOR 1500 MIN⁻¹

EFFICIENCY LEVEL ACCORDING TO IEC 60034-30-2:2016

IE4

VALUES @ 400 V

TEMPERATURE RISE TO CLASS B

Type	Size	Rated speed	Rated power	Rated torque	Peak torque	Voltage constant	Torque constant	BEMF at rated speed	Rated current	Efficiency HPS	Weight
		n 1/min	P _n kW	M _n Nm	M _{pk} Nm	K _e Vs	K _t Nm/A	E _n Vrs	I _n Arms	η %	Kg
1500 min⁻¹											
HPS 56 1500 4	56	1500	0.18	1.2	3.4	1.73	3	272	0.4	72.0%	2.8
HPS 56 1500 5	56	1500	0.25	1.6	4.8	1.73	3	272	0.5	75.4%	3.0
HPS 56 1500 8	56	1500	0.37	2.4	7.1	1.73	3	272	0.8	78.9%	3.2
HPS71 1500 12	71	1500	0.55	3.5	10.5	1.73	3	272	1.2	86.0%	4.8
HPS71 1500 16	71	1500	0.75	4.8	14.4	1.73	3	272	1.6	87.0%	5.4
HPS71 1500 23	71	1500	1.1	7.0	21.0	1.73	3	272	2.3	87.8%	6.2
HPS71 1500 32	71	1500	1.5	9.6	28.8	1.73	3	272	3.2	88.5%	7.0
HPS90 1500 32	S-L	1500	1.5	9.6	28.7	1.73	3	272	3.2	91.0%	10
HPS90 1500 47	S-L	1500	2.2	14.0	42.0	1.73	3	272	4.7	91.5%	12
HPS90 1500 64	S-L	1500	3	19.1	57.3	1.73	3	272	6.4	92.0%	14
HPS90 1500 85	S-L	1500	4	25.5	76.4	1.73	3	272	8.5	92.3%	17
HPS112 1500 85	M	1500	4	25.5	76.4	1.73	3	272	8.5	92.4%	23
HPS112 1500 117	M	1500	5.5	35.0	105.1	1.73	3	272	11.7	92.5%	26
HPS112 1500 159	M	1500	7.5	47.8	143.3	1.73	3	272	15.9	93.1%	30
HPS112 1500 195	M	1500	9.2	58.6	175.8	1.73	3	272	19.5	93.0%	33
HPS132 1500 233	XL	1500	11	70.0	210.1	1.73	3	272	23.3	94.0%	51
HPS132 1500 318	XXL	1500	15	95.5	286.5	1.73	3	272	31.8	94.4%	58
HPS132 1500 393	XXL	1500	18.5	117.8	353.4	1.73	3	272	39.3	94.8%	65
HPS160 1500 233	M	1500	11	70	175	1.73	3	272	23.3	93.3%	70
HPS160 1500 318	M	1500	15	95	239	1.73	3	272	31.8	93.9%	75
HPS160 1500 393	M	1500	18.5	118	294	1.73	3	272	39.3	94.2%	85
HPS160 1500 467	L	1500	22	140	350	1.73	3	272	46.7	94.5%	95
HPS160 1500 637	L	1500	30	191	477	1.73	3	272	63.7	94.9%	115

HPS - STAND ALONE MOTOR 1800 MIN⁻¹

EFFICIENCY LEVEL ACCORDING TO IEC 60034-30-2:2016

IE4

VALUES @ 400 V

TEMPERATURE RISE TO CLASS B

Type	Size	Rated speed	Rated power	Rated torque	Peak torque	Voltage constant	Torque constant	BEMF at rated speed	Rated current	Efficiency HPS	Weight
		n 1/min	P _n kW	M _n Nm	M _{pk} Nm	K _e Vs	K _t Nm/A	E _n Vrs	I _n Arms	η %	Kg
1800 min⁻¹											
HPS 56 1800 4	56	1800	0.18	1.0	2.9	1.45	2.5	272	0.4	72.0%	2.8
HPS 56 1800 5	56	1800	0.25	1.3	4.0	1.45	2.5	272	0.5	75.4%	3.0
HPS 56 1800 8	56	1800	0.37	2.0	5.9	1.45	2.5	272	0.8	78.9%	3.2
HPS71 1800 12	71	1800	0.55	2.9	8.8	1.45	2.5	272	1.2	87.7%	4.8
HPS71 1800 16	71	1800	0.75	4.0	11.9	1.45	2.5	272	1.6	88.4%	5.4
HPS71 1800 23	71	1800	1.1	5.8	17.5	1.45	2.5	272	2.3	88.9%	6.2
HPS71 1800 32	71	1800	1.5	8.0	23.9	1.45	2.5	272	3.2	89.4%	7.0
HPS90 1800 32	S-L	1800	1.5	8.0	23.9	1.45	2.5	272	3.2	91.2%	10
HPS90 1800 46	S-L	1800	2.2	11.7	35.0	1.45	2.5	272	4.6	91.6%	12
HPS90 1800 64	S-L	1800	3	15.9	47.7	1.45	2.5	272	6.3	92.1%	14
HPS90 1800 84	S-L	1800	4	21.2	63.7	1.45	2.5	272	8.4	92.4%	17
HPS112 1800 84	M	1800	4	21.2	63.7	1.45	2.5	272	8.4	92.5%	23
HPS112 1800 116	M	1800	5.5	29.2	87.5	1.45	2.5	272	11.6	92.6%	26
HPS112 1800 158	M	1800	7.5	39.8	119.4	1.45	2.5	272	15.8	93.3%	30
HPS112 1800 232	XL	1800	11	58.4	175.1	1.45	2.5	272	23.2	94.0%	33
HPS132 1800 232	M	1800	11	58.4	175.1	1.45	2.5	272	23.2	94.2%	51
HPS132 1800 317	XXL	1800	15	79.6	238.7	1.45	2.5	272	31.7	94.6%	58
HPS132 1800 391	XXL	1800	18.5	98.1	294.4	1.45	2.5	272	39.1	94.9%	65
HPS160 1800 232	M	1800	11	58	146	1.45	2.5	272	23.2	93.3%	70
HPS160 1800 317	M	1800	15	80	199	1.45	2.5	272	31.7	93.9%	75
HPS160 1800 391	M	1800	18.5	98	245	1.45	2.5	272	39.1	94.2%	75
HPS160 1800 465	L	1800	22	117	292	1.45	2.5	272	46.5	94.5%	85
HPS160 1800 634	L	1800	30	159	398	1.45	2.5	272	63.4	94.9%	100

HPS - STAND ALONE MOTOR

3000 MIN⁻¹

EFFICIENCY LEVEL ACCORDING TO IEC 60034-30-2:2016

IE4

VALUES @ 400 V

TEMPERATURE RISE TO CLASS B

Type	Size	Rated speed	Rated power	Rated torque	Peak torque	Voltage constant	Torque constant	BEMF at rated speed	Rated current	Efficiency HPS	Weight
		n 1/min	P _n kW	M _n Nm	M _{pk} Nm	K _e Vs	K _t Nm/A	E _n Vrs	I _n Arms	η %	Kg
3000 min⁻¹											
HPS56 3000 5	56	3000	0.25	0.8	2.4	0.87	1.5	272	0.5	71.5%	2.6
HPS56 3000 8	56	3000	0.37	1.2	3.5	0.87	1.5	272	0.8	75.6%	2.6
HPS56 3000 12	56	3000	0.55	1.8	5.3	0.87	1.5	272	1.2	79.3%	2.8
HPS56 3000 16	56	3000	0.75	2.4	7.2	0.87	1.5	272	1.6	81.5%	3.0
HPS71 3000 16	71	3000	0.75	2.4	7.2	0.87	1.5	272	1.6	89.7%	4.8
HPS71 3000 23	71	3000	1.1	3.5	10.5	0.87	1.5	272	2.3	90.5%	5.4
HPS71 3000 32	71	3000	1.5	4.8	14.3	0.87	1.5	272	3.2	91.2%	6.0
HPS71 3000 47	71	3000	2.2	7.0	21.0	0.87	1.5	272	4.7	91.4%	6.6
HPS90 3000 47	S-L	3000	2.2	7.0	21.0	0.87	1.5	272	4.7	91.5%	10
HPS90 3000 64	S-L	3000	3	9.6	28.7	0.87	1.5	272	6.4	92.1%	12
HPS90 3000 85	S-L	3000	4	12.7	38.2	0.87	1.5	272	8.5	92.6%	14
HPS90 3000 117	S-L	3000	5.5	17.5	52.5	0.87	1.5	272	11.7	93.1%	16
HPS112 3000 117	M	3000	5.5	17.5	52.5	0.87	1.5	272	11.7	92.9%	23
HPS112 3000 159	M	3000	7.5	23.9	71.6	0.87	1.5	272	15.9	93.7%	26
HPS112 3000 233	M	3000	11	35.0	105.1	0.87	1.5	272	23.3	94.1%	30
HPS112 3000 318	M	3000	15	47.8	143.3	0.87	1.5	272	31.8	94.2%	33
HPS132 3000 318	M	3000	15	47.8	143.3	0.87	1.5	272	31.8	93.8%	51
HPS132 3000 393	XL	3000	18.5	58.9	176.7	0.87	1.5	272	39.3	94.6%	58
HPS132 3000 467	XXL	3000	22	70.0	210.1	0.87	1.5	272	46.7	94.9%	65
HPS132 3000 636	XXL	3000	30	95.4	286.0	0.87	1.5	272	63.6	95.0%	72
HPS160 3000 634	L	3000	30	95.4	239	0.87	1.51	272	63.4	93.7%	90
HPS160 3000 782	L	3000	37	118.0	294	0.87	1.51	272	78.2	94.1%	95

HPS - STAND ALONE MOTOR

3600 MIN⁻¹

EFFICIENCY LEVEL ACCORDING TO IEC 60034-30-2:2016

IE4

VALUES @ 400 V

TEMPERATURE RISE TO CLASS B

Type	Size	Rated speed	Rated power	Rated torque	Peak torque	Voltage constant	Torque constant	BEMF at rated speed	Rated current	Efficiency HPS	Weight
		n 1/min	P _n kW	M _n Nm	M _{pk} Nm	K _e Vs	K _t Nm/A	E _n Vrs	I _n Arms	η %	Kg
3600 min⁻¹											
HPS 56 3600 5	56	3600	0.25	0.7	2.0	0.73	1.26	272	0.5	71.5%	2.6
HPS 56 3600 8	56	3600	0.37	1.0	2.9	0.73	1.26	272	0.8	75.6%	2.6
HPS 56 3600 12	56	3600	0.55	1.5	4.4	0.73	1.26	272	1.2	79.3%	2.8
HPS 56 3600 16	56	3600	0.75	2.0	6.0	0.73	1.26	272	1.6	81.5%	3.0
HPS71 3600 16	71	3600	0.75	2.0	6.0	0.73	1.26	272	1.6	90.0%	4.8
HPS71 3600 23	71	3600	1.1	2.9	8.8	0.73	1.26	272	2.3	90.9%	5.4
HPS71 3600 32	71	3600	1.5	4.0	11.9	0.73	1.26	272	3.2	91.6%	6.0
HPS71 3600 46	71	3600	2.2	5.8	17.5	0.73	1.26	272	4.6	91.8%	6.6
HPS90 3600 46	S-L	3600	2.2	5.8	17.5	0.73	1.26	272	4.6	91.7%	10
HPS90 3600 63	S-L	3600	3	8.0	23.9	0.73	1.26	272	6.3	92.4%	12
HPS90 3600 84	S-L	3600	4	10.6	31.8	0.73	1.26	272	8.4	92.8%	14
HPS90 3600 116	S-L	3600	5.5	14.6	43.8	0.73	1.26	272	11.6	93.3%	16
HPS112 3600 116	M	3600	5.5	14.6	43.8	0.73	1.26	272	11.6	93.2%	23
HPS112 3600 158	M	3600	7.5	19.9	59.7	0.73	1.26	272	15.8	93.9%	26
HPS112 3600 232	M	3600	11	29.2	87.5	0.73	1.26	272	23.2	94.3%	30
HPS112 3600 317	M	3600	15	39.8	119.4	0.73	1.26	272	31.7	94.5%	33
HPS132 3600 317	M	3600	15	39.8	119.4	0.73	1.26	272	31.7	94.2%	51
HPS132 3600 391	XL	3600	18.5	49.1	147.2	0.73	1.26	272	39.1	94.6%	58
HPS132 3600 465	XXL	3600	22	58.4	175.1	0.73	1.26	272	46.5	95.0%	65
HPS132 3600 634	XXL	3600	30	79.6	238.7	0.73	1.26	272	63.4	95.1%	72
HPS160 3600 629	L	3600	30	79.6	199	0.73	1.26	272	62.9	93.7%	85
HPS160 3600 776	L	3600	37	98.0	245	0.73	1.26	272	77.6	94.1%	90

HPS - STAND ALONE MOTOR

4500 MIN⁻¹

EFFICIENCY LEVEL ACCORDING TO IEC 60034-30-2:2016

IE4

VALUES @ 400 V

TEMPERATURE RISE TO CLASS B

Type	Size	Rated speed	Rated power	Rated torque	Peak torque	Voltage constant	Torque constant	BEMF at rated speed	Rated current	Efficiency HPS	Weight
		n 1/min	P _n kW	M _n Nm	M _{pk} Nm	K _e Vs	K _t Nm/A	E _n Vrs	I _n Arms	η %	Kg
4500 min⁻¹											
HPS 56 4500 8	56	4500	0.37	0.8	2.4	0.58	1.00	272	0.8	75.6%	2.6
HPS 56 4500 12	56	4500	0.55	1.2	3.5	0.58	1.00	272	1.2	79.3%	2.6
HPS 56 4500 16	56	4500	0.75	1.6	4.8	0.58	1.00	272	1.6	81.5%	2.8
HPS 56 4500 23	56	4500	1.1	2.3	7.0	0.58	1.00	272	2.3	83.3%	3.0
HPS71 4500 23	71	4500	1.1	2.3	7.0	0.58	1	272	2.3	90.0%	4.8
HPS71 4500 32	71	4500	1.5	3.2	9.6	0.58	1	272	3.2	91.0%	5.4
HPS71 4500 47	71	4500	2.2	4.7	14.0	0.58	1	272	4.7	91.8%	6.2
HPS71 4500 64	71	4500	3	6.4	19.1	0.58	1	272	6.4	91.9%	7.0
HPS90 4500 64	S-L	4500	3	6.4	19.1	0.58	1	272	6.4	91.8%	10
HPS90 4500 85	S-L	4500	4	8.5	25.5	0.58	1	272	8.5	92.4%	12
HPS90 4500 117	S-L	4500	5.5	11.7	35.0	0.58	1	272	11.7	93.0%	14
HPS90 4500 159	S-L	4500	7.5	15.9	47.8	0.58	1	272	15.9	93.5%	17

HPS FRAME SIZE 56 - 71 - 90 - 112 IM B3 ALUMINIUM ALLOY FRAME (METRIC)

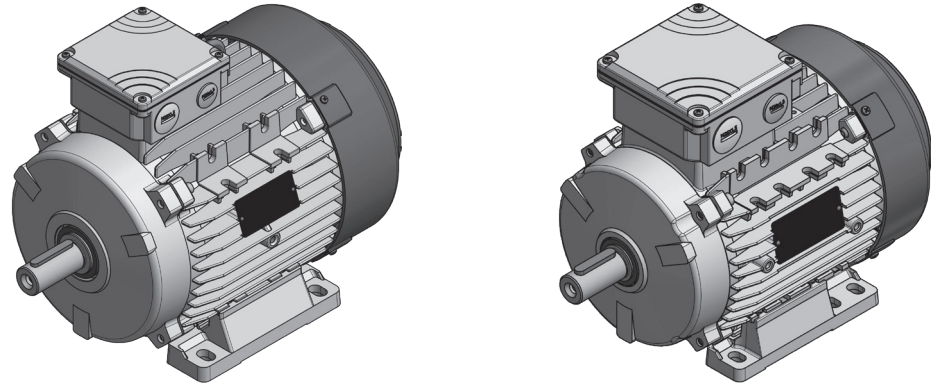

ONLY FOR SIZE 90L

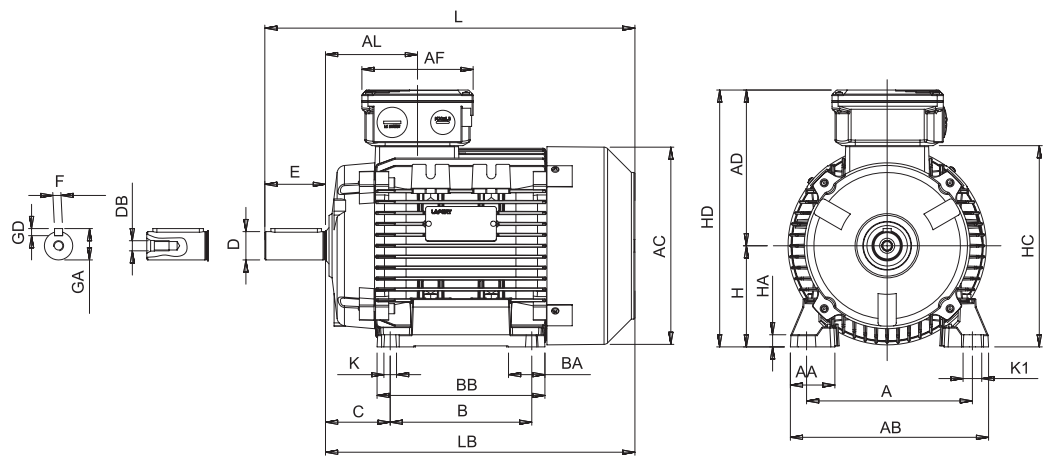

	IEC	H	A	B	C	K ¹⁾	AB	BB	AD ²⁾	HD ²⁾	AC	HC	HA
56		56	90	71	36	6	107	86	92	148	110	109	8
71		71	112	90	45	8	135	108	114	185	142	142	9
90S		90	140	100	56	10	170	150	148	238	177	181	11
90L		90	140	125	56	10	170	150	148	238	177	181	11
112M		112	190	140	70	12.5	220	176	171	283	225	226	15
112XL		112	190	140	70	12.5	220	176	171	283	225	226	15

	IEC	K1	L	LB	AL	AF	BA	AA	D	E	F	GD	GA	DB ³⁾
56		9	188	168	61	93	27	27	14	30	5	5	16	M5
71		17	245	215	75	93	22	30	19	40	6	6	22	M6
90S		15	317	267	85	110	28/53	37	24	50	8	7	27	M8
90L		15	317	267	85	110	28/53	37	24	50	8	7	27	M8
112M		19	388	328	92	110	46	48	28	60	8	7	31	M10
112XL		19	410	350	92	110	46	48	28	60	8	7	31	M10

- 1) Clearance hole for screw
- 2) Maximum dimension
- 3) Centering holes in shaft extensions to DIN 332 part 2

HPS FRAME SIZE 132 IM B3 ALUMINIUM ALLOY FRAME (METRIC)

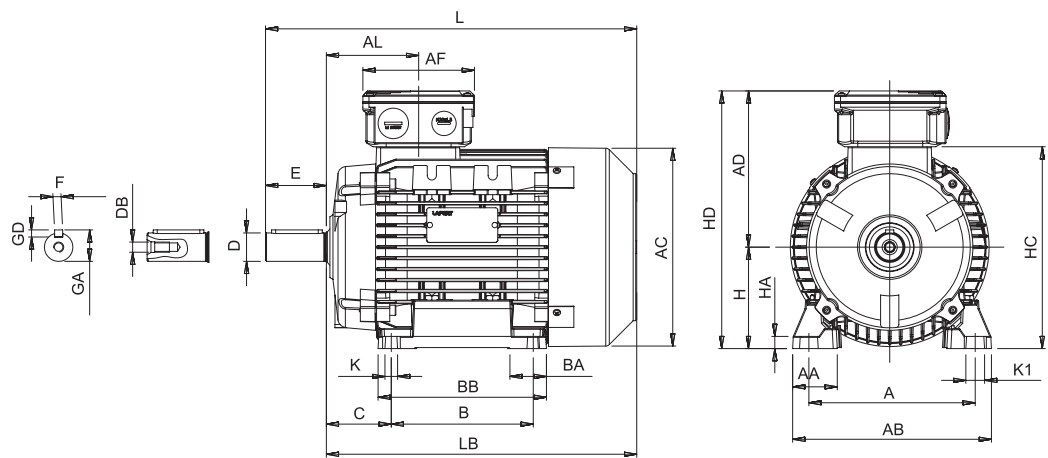
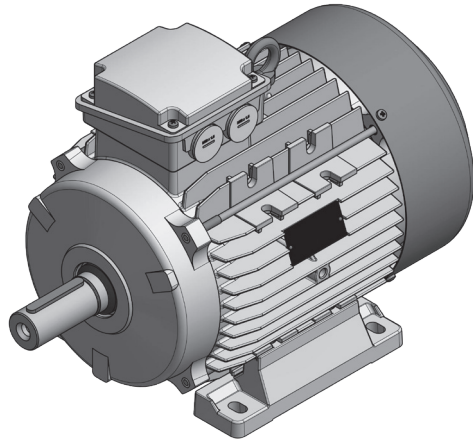

IEC	H	A	B	C	K ⁽¹⁾	AB	BB	AD ⁽²⁾	HD ⁽²⁾	AC	HC	HA
132M	132	216	178	89	12	256	218	195	327	248	261	17
132XL	132	216	178	89	12	256	218	195	327	248	261	17
132XXL	132	216	178	89	12	256	218	195	327	248	261	17

IEC	K1	L	LB	AL	AF	BA	AA	D	E	F	GD	GA	DB ⁽³⁾
132M	20	485	405	122	133	45	59	38	80	10	8	41	M12
132XL	20	505	425	122	133	45	59	38	80	10	8	41	M12
132XXL	20	556	476	122	133	45	59	38	80	10	8	41	M12

1) Clearance hole for screw

2) Maximum dimension

3) Centering holes in shaft extensions to DIN 332 part 2

HPS FRAME SIZE 160 IM B3 ALUMINIUM ALLOY FRAME (METRIC)

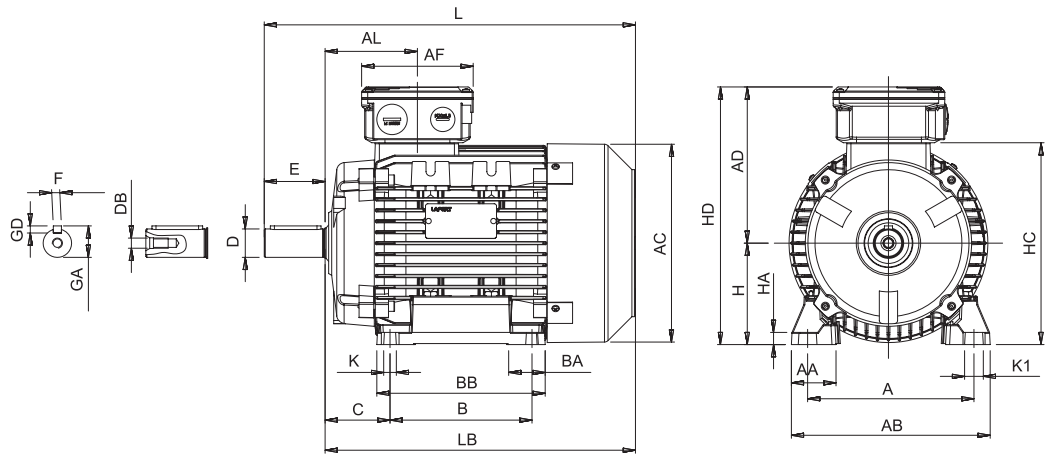
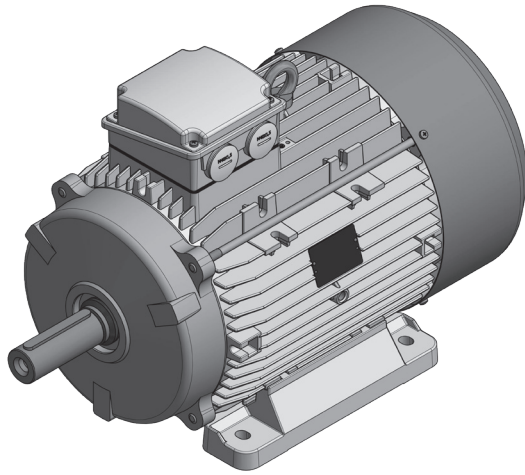

IEC	H	A	B	C	K ¹⁾	AB	BB	AD ²⁾	HD ²⁾	AC	HC	HA
160M	160	254	210	108	14	320	270	238	398	317	316	23
160L	160	254	254	108	14	320	310	238	398	317	316	23

IEC	K1	L	LB	AL	AF	BA	AA	D	E	F	GD	GA	DB ³⁾
160M	18	608	498	146	150	65	76	42*	110	12*	8*	45*	M16
160L	18	652	542	168	150	65	76	48	110	14	9	51.5	M16

1) Clearance hole for screw

2) Maximum distance

3) Centering holes in shaft extensions to DIN 332 part 2

* For type HPS 160M 18.5kW, please refer to HPS 160L

HPS FRAME SIZE 56 - 71 - 90 - 112 - 132 - 160 IM B14, IM B5 ALUMINIUM ALLOY FRAME (METRIC)

IM B14

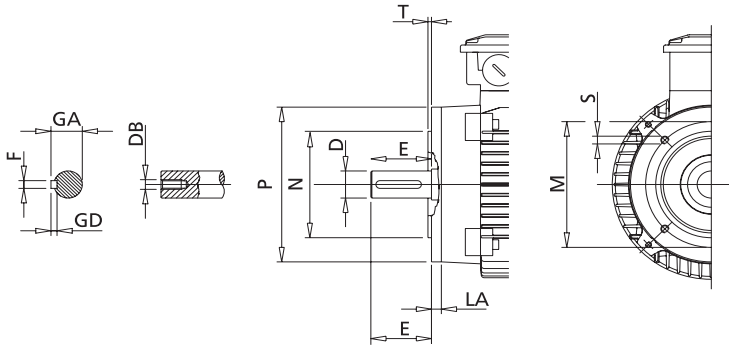

IM B5

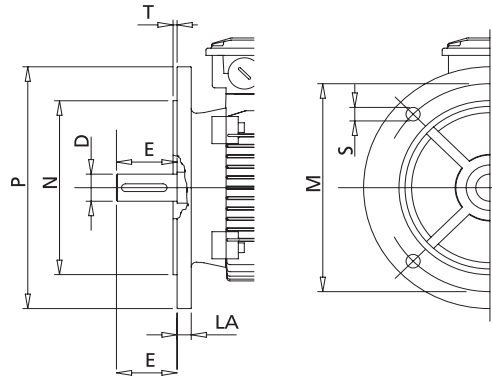

IEC	SMALL FLANGE B14						LARGE FLANGE B14						FLANGE B5					
	P	N	LA	M	T	S ¹⁾	P	N	LA	M	T	S ¹⁾	M	N	P	T	LA	S ¹⁾
56	80	50	8	65	2.5	M5	105	70	8	85	2.5	M6	100	80	120	2.5	7	M6
71	105	70	11	85	2.5	M6	140	95	8	115	3	M8	130	110	160	3.5	10	M8
90S-L	140	95	10	115	3	M8	160	110	9	130	3.5	M8	165	130	200	3.5	12	M10
112M-XL	160	110	10	130	3.5	M8	200	130	12	165	3.5	M10	215	180	250	4	14	M12
132M-XL-XXL	200	130	23	165	3.5	M10	250	180	12	215	4	M12	265	230	300	4	14	M12
160M-L	250	180	20	216	4	M12	300	230	12	265	5	M16	300	250	350	5	15	M16

1) Clearance hole for screw

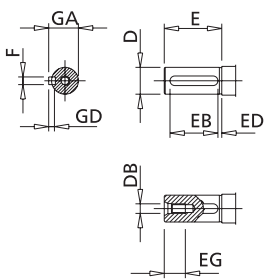

IEC	D	E	F h9	GD	GA	DB	EG	EB	ED
56	14	30	5	5	16	M5	12.5	20	4
71	19 j6	40	6	6	22	M6	16	30	4
90S-L	24 j6	50	8	7	27	M8	19	40	4
112M-XL	28 j6	60	8	7	31	M10	22	50	4
132M-XL-XXL	38 k6	80	10	8	41	M12	28	70	4
160M	42 k6*	110	12*	8*	45*	M16	36	100	4
160L	48k6*	110	14	9	51.5	M16	36	100	4

1) Centring holes in shaft extension to DIN 332 part 2

HPS FRAME SIZE 71 NEMA 56C ALUMIUM ALLOY FRAME

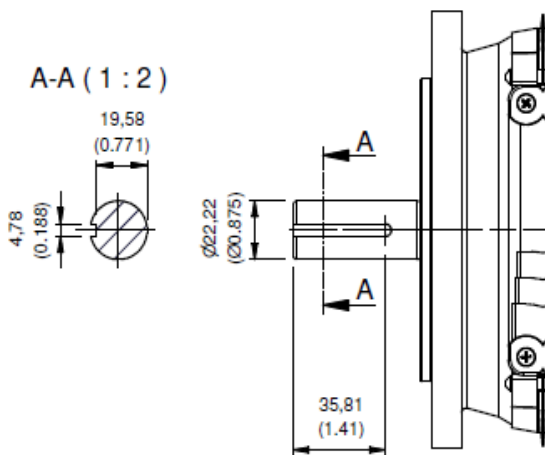
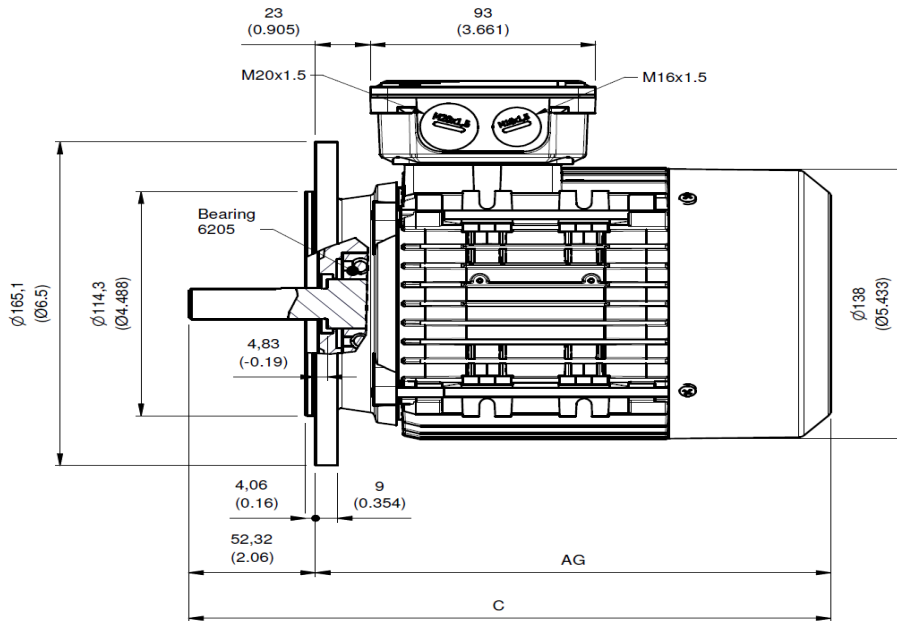
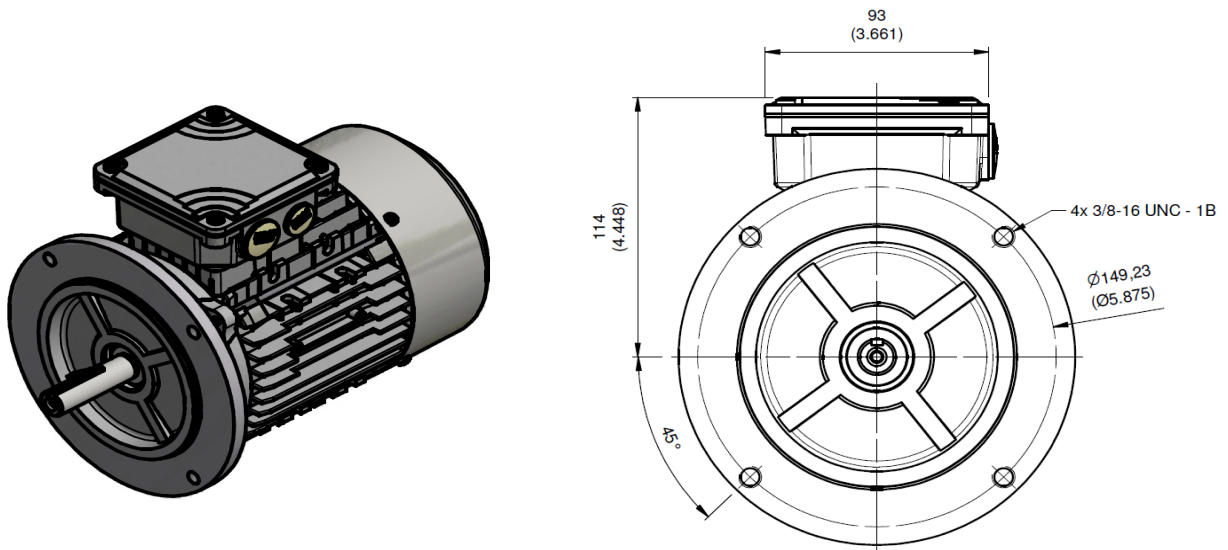

Rated Speed (RPM)	Rated Power (kW)	Rated Power (HP)	AG	C
1500	0.55	0.75	213 (8.386)	265 (10.433)
	0.75	1		
	1.1	1.5		
	1.5	2		
1800	0.55	0.75		
	0.75	1		
	1.1	1.5		
3000	1.5	2		
	2.2	3		
	0.75	1		
	1.1	1.5		
3600	1.5	2		
	2.2	3		
	0.75	0.75		
4500	1.1	1.5		
	1.5	2		
	2.2	3		
	3	4		

Note: Dimensions in brackets are in inches

HPS FRAME 90 NEMA 143TC-145TC
ALUMIUM ALLOY FRAME

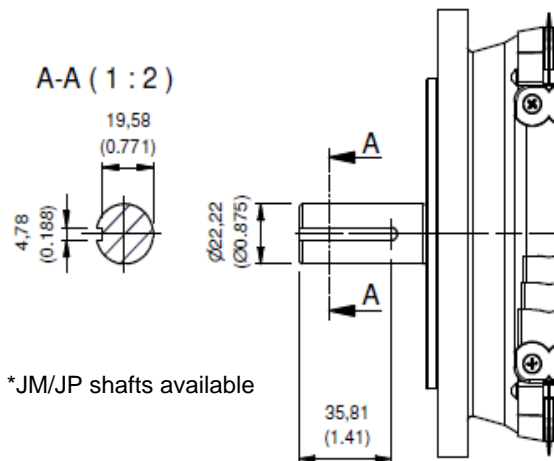
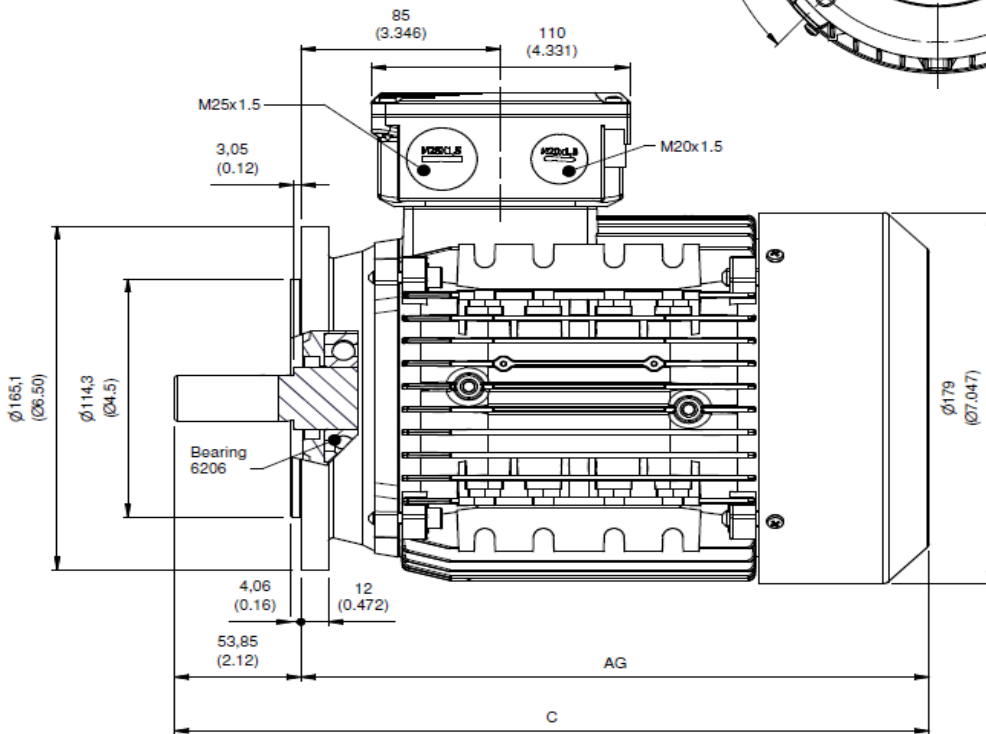
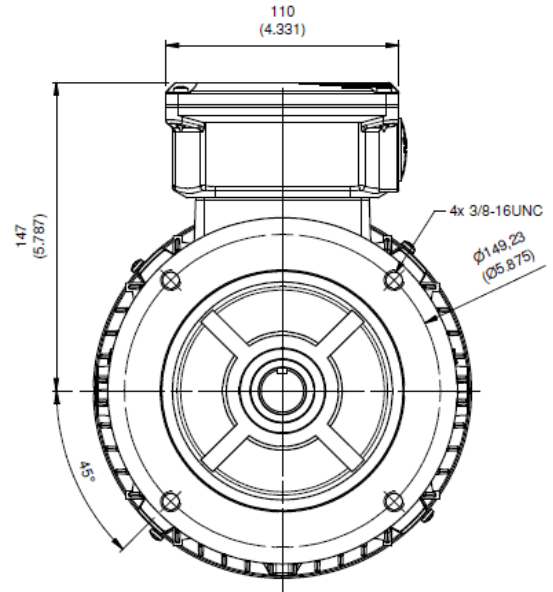
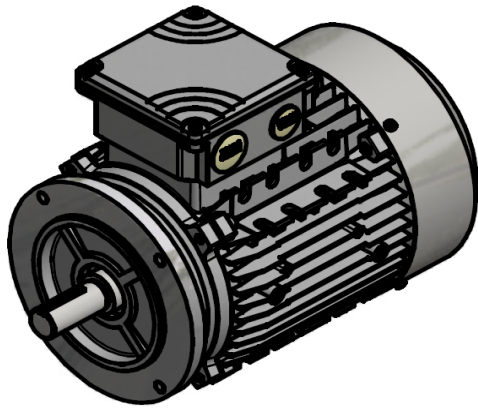

*JM/JP shafts available

Rated Speed (RPM)	Rated Power (kW)	Rated Power (HP)	AG	C
1500	1.5	2	267 (10.512)	321 (12.638)
	2.2	3		
	3	4		
	4	5		
1800	1.5	2		
	2.2	3		
	3	4		
	4	5		
3000	2.2	3		
	3	4		
	4	5		
	5.5	7.5		
3600	2.2	3		
	3	4		
	4	5		
4500	5.5	7.5		
	3	4		
	4	5		
	7.5	10		

Note: Dimensions in brackets are in inches

HPS FRAME SIZE 112M NEMA B5 ALUMIUM ALLOY FRAME

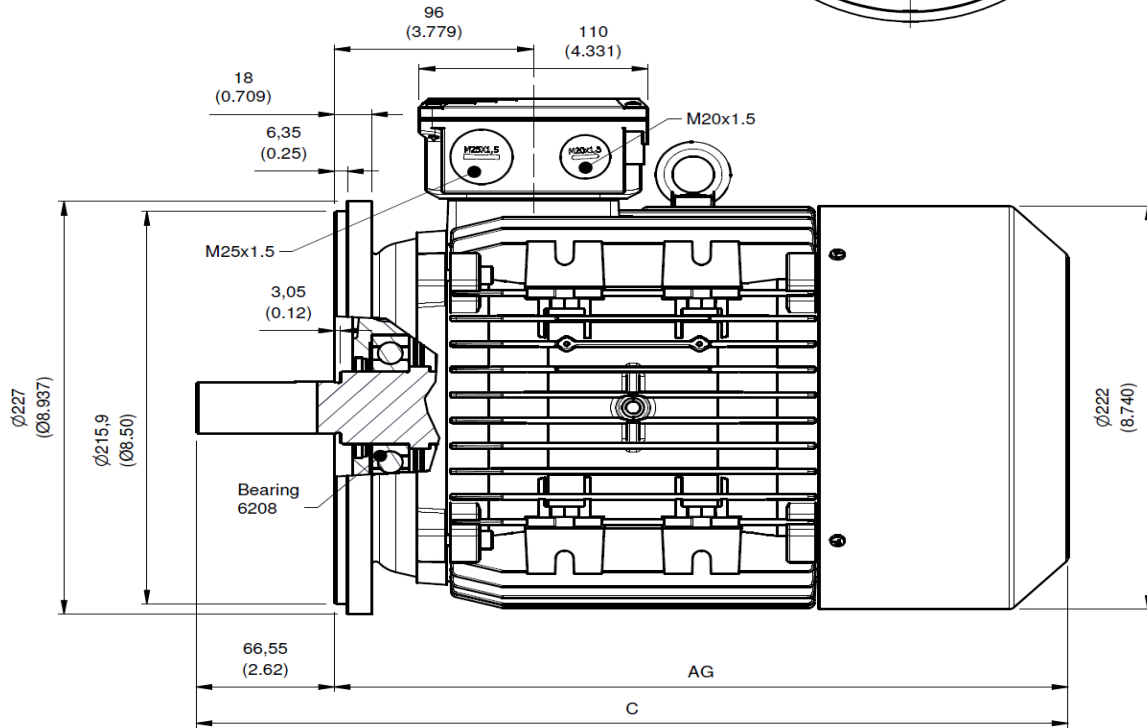
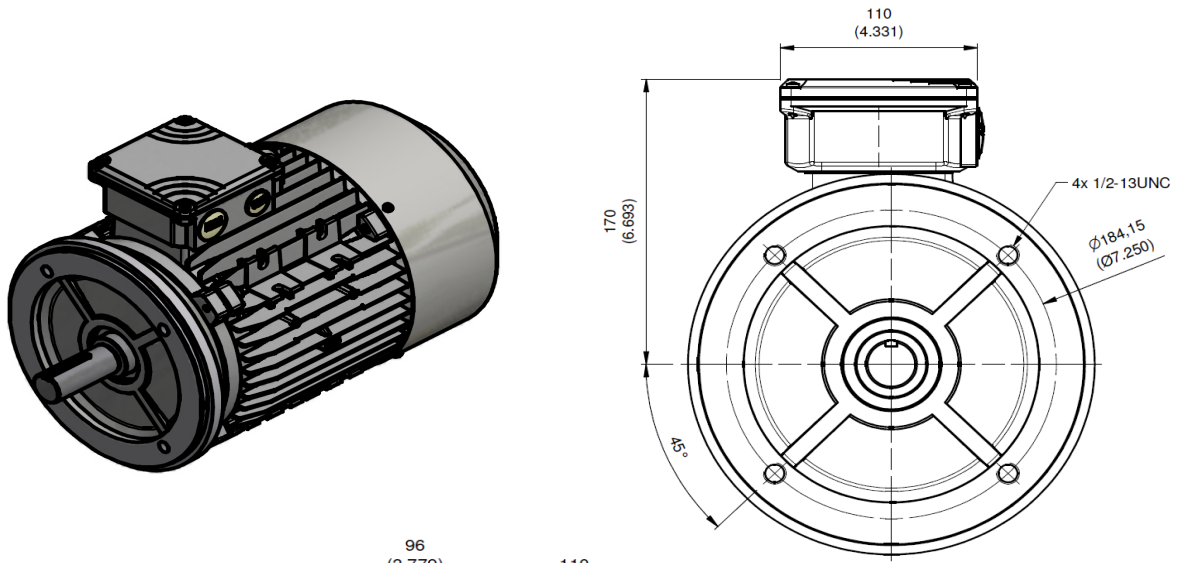

A-A (1 : 2.5)

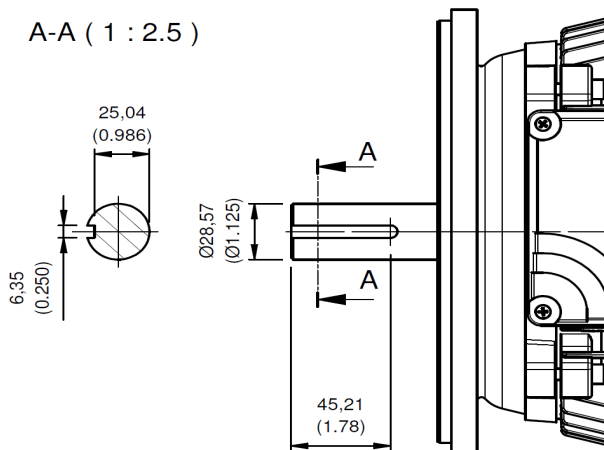

Rated Speed (RPM)	Rated Power (kW)	Rated Power (HP)	AG	C
1500	4	5	331.5 (13.051)	398 (13.669)
	5.5	7.5		
	7.5	10	353 (139.173)	420 (16.535)
1800	4	5	331.5 (13.051)	398 (13.669)
	5.5	7.5		
	7.5	10	353 (139.173)	420 (16.535)
3000	5.5	7.5	331.5 (13.051)	398 (13.669)
	7.5	10		
	11	15		
3600	15	20	331.5 (13.051)	398 (13.669)
	5.5	7.5		
	7.5	10		
	11	15		
	15	20		

Note: Dimensions in brackets are in inches

HPS FRAME SIZE 132 NEMA 213TC-215TC
ALUMIUM ALLOY FRAME

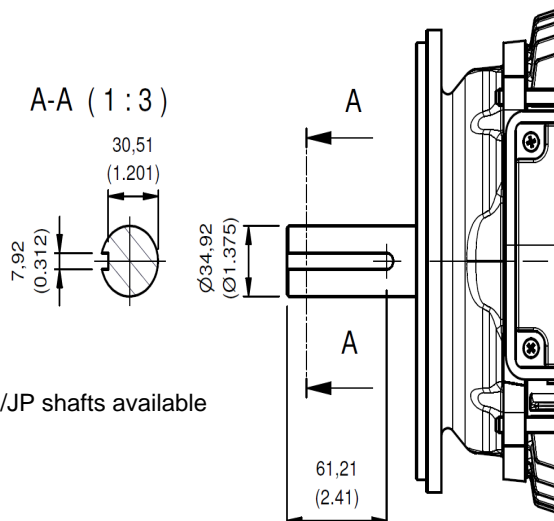
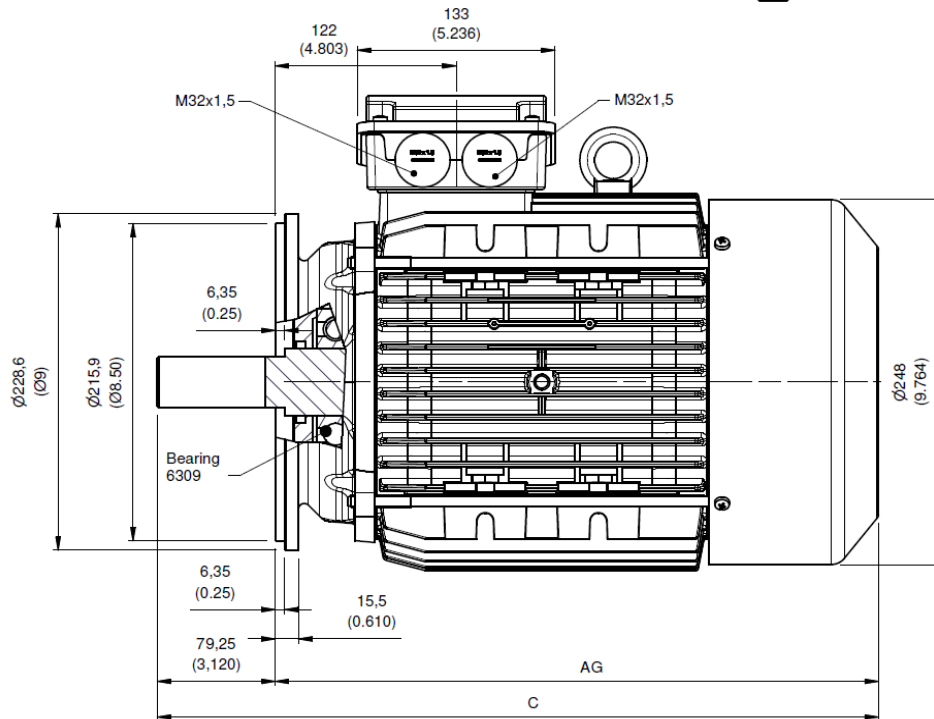
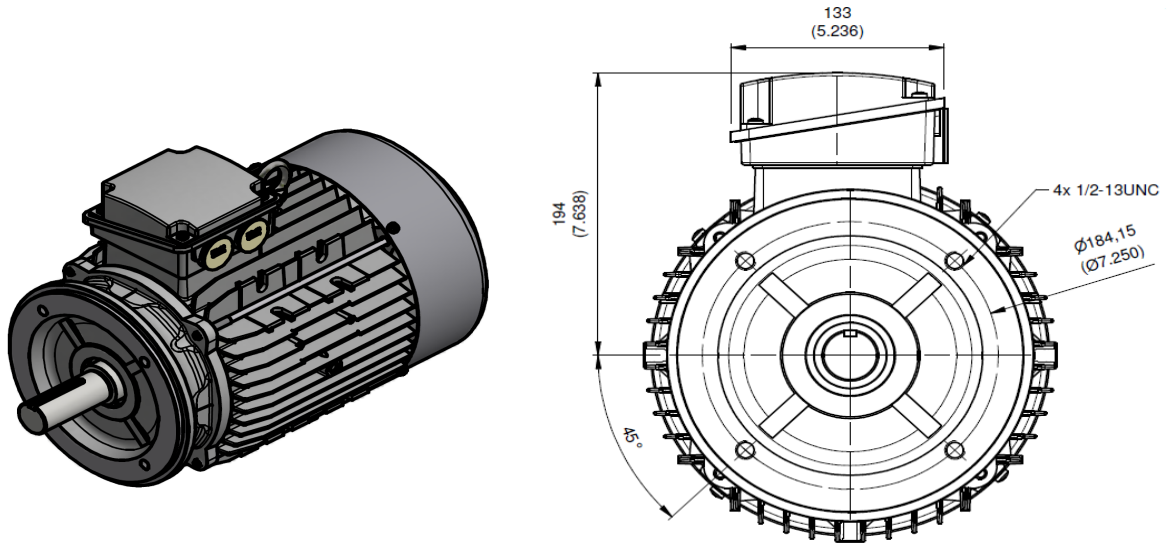

*JM/JP shafts available

Rate d Speed (RPM)	Rated Power (kW)	Rated Power (HP)	AG	C
1500	11	15	425 (16.732)	504.25 (19.852)
	15	20	476 (18.740)	555.25 (21.860)
	18.5	25		
1800	11	15	425 (16.732)	504.25 (19.852)
	15	20	476 (18.740)	555.25 (21.860)
	18.5	25		
3000	15	20	405 (15.945)	484 (19.055)
	18.5	25	425 (16.732)	504.25 (19.852)
	22	30		
3600	30	40	476 (18.740)	555.25 (21.860)
	15	20	405 (15.945)	484 (19.055)
	18.5	25	425 (16.732)	504.25 (19.852)
3600	22	30		
	30	40	476 (18.740)	555.25 (21.860)

Note: Dimensions in brackets are in inches

Branches & Partners

Lafert GmbH

Wolf-Hirth-Straße 10
D-71034 Böblingen
Germany
Phone +49 175 550 4526
lafert.germany@lafert.com

Lafert Electric Motors Ltd.

Unit 17 Orion Way
Crewe, Cheshire CW1 6NG
United Kingdom
Phone +44 / (0) 1270 270 022
Fax +44 / (0) 1270 270 023
lafertuk@lafert.com

Lafert Moteurs S.A.S.

L'Isle d'Abeau Parc de Chesnes
75, rue de Malacombe
F - 38070 St. Quentin-Fallavier France
Phone +33 / 474 95 41 01
Fax +33 / 474 94 52 28
info.lafertmoteurs@lafert.com

Lafert Motores Eléctricos, S.L.

Poligono Pignatelli, Nave 27
E - 50410 Cuarte de Huerva
(Zaragoza) - Spain
Phone +34 / 976 503 822
Fax +34 / 976 504 199
info@lafert.es

Lafert N.A. (North America)

5620 Kennedy Road - Mississauga
Ontario L4Z 2A9 - Canada
Phone +1 / 800/661 6413 - 905/629 1939
Fax +1 / 905/629 2852
sales@lafertna.com

Lafert Electric Motors (Australia)

Factory 3, 117-123 Abbott Road,
Hallam - VIC 3803 - Australia
Phone +61 / (0)3 95 46 75 15
Fax +61 / (0)3 95 47 93 96
info@lafertaust.com.au

Lafert Singapore Pte Ltd

48 Hillview Terrace #06-06
Hillview Building - Singapore 669269
Phone +65 / 67630400 - 67620400
Fax +65 / 67630600
info@lafert.com.sg

Lafert (Suzhou) Co., Ltd.

No.3 Industrial Plant Building Yue Xi Phase 3,
Tian E Dang Lu 2011, 15104 Wu Zhong
Economic Development Zone, Suzhou, China
Phone +86 / 512 6687 0618
Fax +86 / 512 6687 0718
info.lafertsuzhou@lafert.com

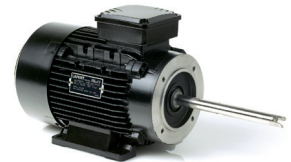

AC MOTORS - IE3, IE2



BRAKE MOTORS



HIGH PERFORMANCE MOTORS - IE4



SERVO MOTORS & DRIVES

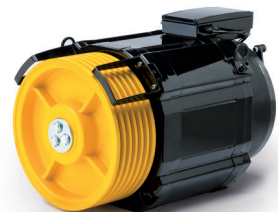

LIFT MOTORS

